

# OWNER'S MANUAL

## BSEF SERIES

Self Priming Centrifugal Pumps  
for liquid fertilizer  
(Type A)



### SAFETY WARNINGS



**BEFORE OPERATING OR INSTALLING THIS PUMP, READ THIS MANUAL AND FOLLOW ALL SAFETY RULES AND OPERATING INSTRUCTIONS.**

 **SAFETY CAREFULLY READ THESE SAFETY MESSAGES IN THIS MANUAL AND ON PUMP.**

### CAUTION

- **DO NOT OPERATE THIS PUMP DRY!**
- Review instructions before operating.

### WARNING - ELECTRICAL PRECAUTIONS

All wiring, electrical connections, and system grounding must comply with the National Electrical Code (NEC) and with any local codes and ordinances. Employ a licensed electrician. For non-thermally protected motors use with approved motor control that matches motor input in full load amperes with overload element(s) selected or adjusted in accordance with control instructions.

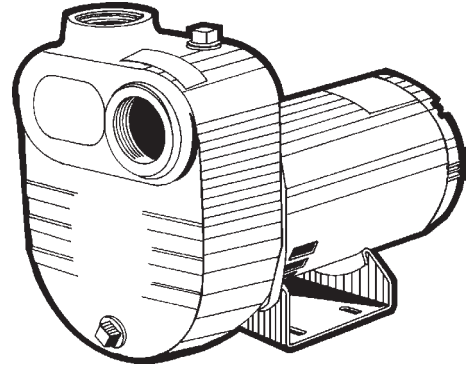

### WARNING - RISK OF ELECTRICAL SHOCK

- Review chemical manufacturer's safety precautions before handling.
- Make sure all connections are tight.
- Do not breathe or ingest fumes or chemicals.
- Never use with flammable fluids.
- Have an electrician provide electrical power to motor.
- Motor must be grounded and terminal cover in place to reduce electrical shock hazard.
- Keep motor operating area as dry as possible.
- Always disconnect power before servicing.
- Not investigated for use in swimming pool areas.

## APPLICATION

These pumps are suitable for transferring liquid fertilizer, where the vertical distance from the pump to the liquid level does not exceed 25 ft. (7.6m). The elevation above sea level and friction losses must be taken into consideration.

This pump has been tested and operated under actual working conditions. Motor, pump and all accessories found satisfactory. If pumping unit is not performing as specified, check installation and follow instructions carefully.

## PERFORMANCE

Model	HP	Total Head in Feet									
		20	25	30	35	40	45	50	55	60	65
BSEF-S75	3/4	49	43	37	29	23	14	4			
BSEF-S100	1		59	50	41	34	24	13	3		
BSEF-S150	1 1/2			70	66	62	54	40	31	17	4
BSEF-S200	2	97	92	86	76	67	56	43	34	22	10

Model	HP	Total Head in Feet							
		20	30	40	50	60	70	80	90
BSEF-300	3	130	126	115	98	73	44	17	
BSEF-500	5	266	237	207	169	124	60		
BSEF-750	7 1/2	292	270	245	214	173	122	68	0

## INSTALLATION

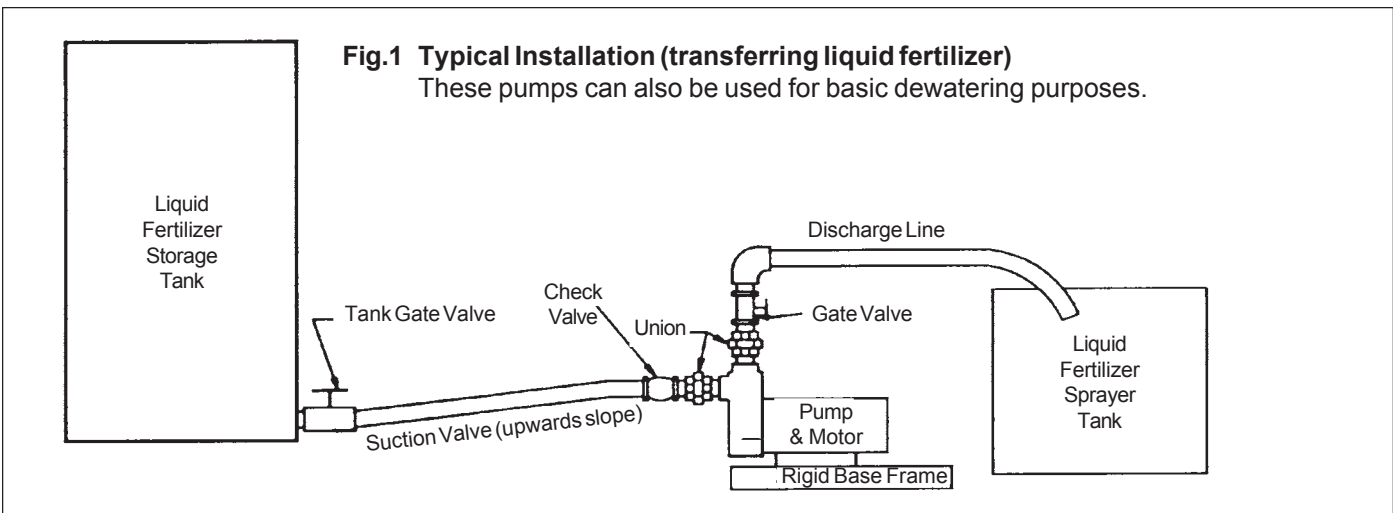

- a) **LOCATION:** (Refer to Fig. 1) If the pump is intended to be permanently installed, the location should be clean, dry and ventilated. It should also provide adequate room for drainage and servicing.  
  
The pump should always be located as close as possible to the source of liquid it will be pumping. This will keep the friction losses at a minimum and pumping capacities as high as possible.
- b) **MOUNTING:** The pump should be firmly fixed to a rigid foundation, to eliminate creeping due to vibration when operating the pump.
- c) **SUCTION LINE:** It is recommended that the size of the suction line be the same as the tapping size on the pump casing. If the pump is installed any appreciable distance away from the source of liquid supply, the suction line should be increased by one size. The suction line must always slope upwards to the pump to avoid air pockets in the line.
- d) **SUCTION PIPE:** Use thread compound on all pipe joints. Connections must be tight. Clean, uncorroded pipe is recommended.
- e) **SUCTION HOSE:** If the suction line runs basically vertical, use an elbow on the hose to prevent kinking. Use thread compound on all hose joints. Connections must be tight.
- f) **WIRING:** It is recommended that a separate circuit be used from the distribution panel to the pump. A proper fused disconnect switch is to be installed in the line, making sure that the correct gauge of cable is used to carry the load. Very long leads will require a larger cable.
- g) **IMPELLER ROTATION:** To make sure that the motor has been wired correctly for this pump, remove the cap off of the back end of the motor. Turn the pump on for one second. The shaft should be turning in a clockwise direction as viewed from the back end of the motor, in order to achieve the proper impeller rotation.

Note: An electrician should be employed to do the wiring.

## OPERATION - PRIMING THE PUMP

 **WARNING:** DO NOT RUN THE PUMP BEFORE PRIMING IT, SINCE THE SEAL AND IMPELLER COULD BE PERMANENTLY DAMAGED.

- a) **PREPARING THE MOTOR:** Check the motor manufacturer's instructions for any preparations required before operating.
- b) **PRIMING THE PUMP:** Remove the priming plug and fill the casing with the same liquid that you will be pumping. If the suction line is below the level of the liquid that will be pumped, this is known as a "flooded suction" situation, whereby the pump will automatically fill up when the valves are open. Then turn the pump on.

 **CAUTION:** Never operate the pump dry!

- c) **START-UP:** In a "flooded suction" situation the pump will discharge the liquid almost immediately.

If the suction line is above the liquid level being pumped, it will take a few minutes to lift the water to the casing, and then, to discharge it.

If the suction line is quite long, the pump may overheat before the liquid in the suction line reaches the pump. In this case, turn the pump off and drain the casing. Wait a few minutes for the seal in the pump casing to cool down; then replace the drain plug and refill the casing with the same liquid that will be pumped. Replace the priming plug and restart the pump.

 **WARNING:** If the "overheated" casing is filled while hot, damage to the seal will occur.

## MAINTENANCE

### **WARNING - ELECTRICAL PRECAUTIONS**

All wiring, electrical connections, and system grounding must comply with the National Electrical Code (NEC) and with any local codes and ordinances. Employ a licensed electrician.

### **WARNING - RISK OF ELECTRICAL SHOCK**

Before servicing motor operated equipment, shut off the power at the main electrical panel and disconnect the power supply from the motor and the accessories. Use safe working practices during servicing of equipment.

- a) **THE MOTOR:** Refer to the motor manufacturer's instructions for any maintenance requirements.
- b) **DRAINING:** If the pump is subject to freezing temperatures, it will be necessary to drain the pump completely. Remove the drain plug and the priming plug. Make sure that the drain hole is not choked. After all of the water has been drained, turn the pump on for a few seconds to devoid the impeller of any liquid. Make sure that the lines are also free of liquid.
- c) **STORAGE:** It is recommended to use a good rust inhibitor in the casing after draining procedure has been completed.

### DISASSEMBLY:

- 1) Drain the pump (see "draining").
- 2) Disconnect the pipe/hoses.
- 3) To remove the casing (1), remove the bolts (on a BSEF-S200, remove the nuts) from the adapter.
- 4) To remove the impeller (2), remove the cap off of the back end of the motor and insert a screwdriver into the slot on the shaft. Unscrew the impeller in a counter-clockwise direction.
- 5) To remove the seal (7), simply pull it off of the shaft.
- 6) To remove the adapter (5), simply pull it out.

**⚠ CAUTION:** Be careful not to damage the motor shaft (6) when removing the seal plate.

- 7) To remove the ceramic seat (8), press it out from the backside of the seal plate.
- 8) Remove the rubber cup (4).
- 9) Do not remove the flinger (9), unless it needs to be replaced.

### REASSEMBLY:

- 1) Clean all parts thoroughly before reassembly.

Refer to Fig. 2, to reassemble the following items.

- 2) Insert the ceramic seat (8) into the rubber cup (4). Make sure that the smooth face of the ceramic seat is facing towards the front of the pump. Oil the rubber cup and push this assembly into the seal plate, using hand pressure only.
- 3) Slide the seal plate assembly into position. Make sure that the flinger (9) is on the shaft.

**⚠ CAUTION:** Be careful not to damage the ceramic seat, or shaft when reassembling the seal plate to the motor.

- 4) Slide the sleeve (7), onto the shaft.
- 5) Screw on the impeller (2) clockwise, while securing the screw on the back end of the motor.

Fig. 2

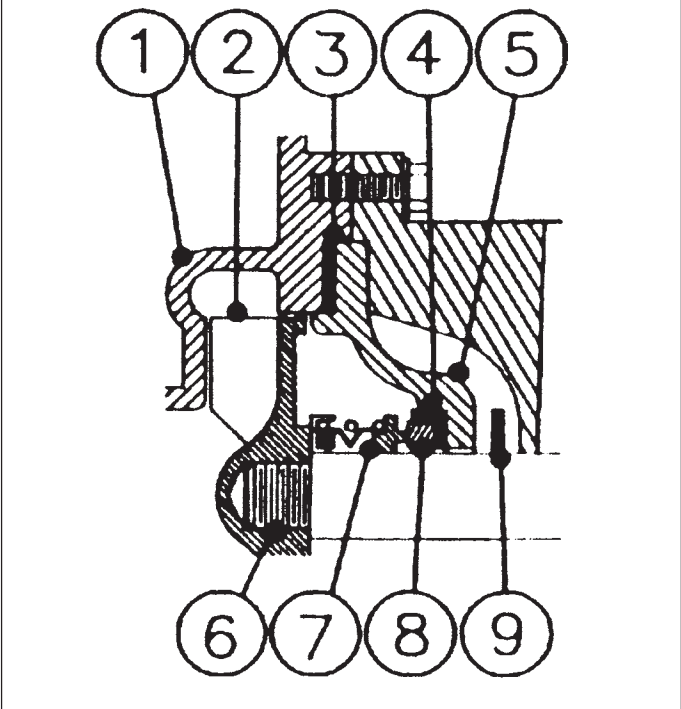

- 6) Replace the gasket (3) and the washers. Then assemble the casing onto the motor.

### PRECAUTION:

Check to see that the impeller rotates freely in the casing.

- 7) Reconnect the suction and discharge lines. Use a thread compound and make sure that the connections are tight.

### DISASSEMBLY:

- 1) Drain the pump (see "draining").
- 2) Disconnect the pipe/hoses.
- 3) To remove the casing (2), remove the nuts (on a BSEF-300, remove the bolts) from the adapter.
- 4) To remove the impeller (3), remove the cap off of the back end of the motor and insert a screwdriver into the slot on the shaft. Unscrew the impeller, or the bolt (1) in a counter-clockwise direction.
- 5) To remove the seal (8), simply pull it off of the shaft. On a BSEF-500 & 750, the sleeve (11) will come with it.
- 6) To remove the adapter (6), remove the bolts and pull the adapter off.

**CAUTION:** Be careful not to damage the motor shaft (7) when removing the adapter.

- 7) To remove the ceramic seat (9), press it on from the backside of the seal plate.
- 8) Remove the rubber cup (5).
- 9) Do not remove the flinger (10), unless it needs to be replaced.

### REASSEMBLY:

- 1) Clean all parts thoroughly before reassembly.  
Refer to Fig. 3, to reassemble the following items.

- 2) Insert the ceramic seat (9) into the rubber cup (5). Make sure that the smooth face of the ceramic seat is facing towards the front of the pump. Oil the rubber cup and push this assembly into the adapter (6), using hand pressure only.
- 3) Bolt the adapter assembly onto the motor. Make sure that the flinger (10) is on the shaft.

**CAUTION:** Be careful not to damage the ceramic seat, or shaft when reassembling the sleeve to the motor.

- 4) Slide the sleeve (11), except for the BSEF-300, and the seal (8) onto the shaft. Insert the key into the slot in the sleeve.
- 5) Reassemble the impeller (3).

Fig. 3

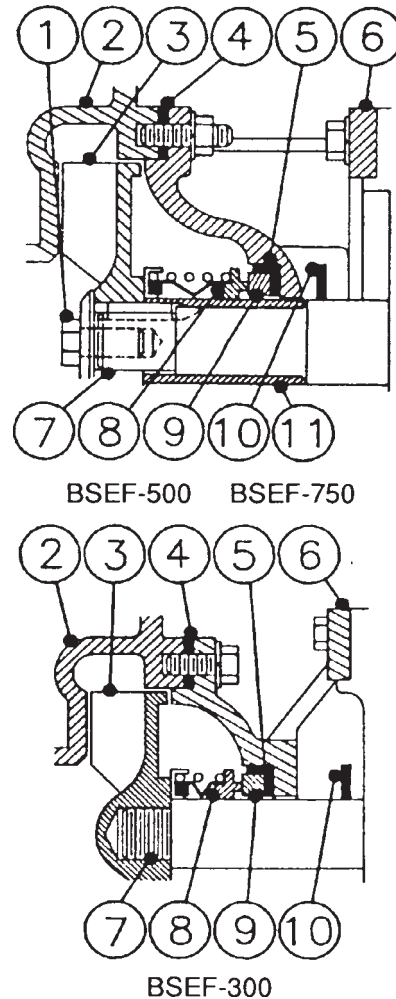

- 6) Replace the gasket (4) and the washers. Then assemble the casing (2) onto the adapter.

### PRECAUTION:

Check to see that the impeller rotates freely in the casing.

- 7) Reconnect the suction and discharge lines. Use a thread compound and make sure that the connections are tight.

## TROUBLESHOOTING GUIDE

PROBLEMS	CAUSES	SOLUTIONS
<b>Pump will not pump</b>	<ul style="list-style-type: none"> <li>• The suction and/or discharge line(s) may be blocked, or the valve(s) are closed, faulty and/or blocked.</li> <li>• The end of the suction line is not submerged.</li> <li>• Incorrect impeller rotation.</li> <li>• Total head is too high for what this pump has been designed for.</li> </ul>	<ul style="list-style-type: none"> <li>• Check to see that the lines and valves are in good working order.</li> <li>• Increase its length, or move the pump closer.</li> <li>• Check wiring.</li> <li>• Reduce total head or use a higher head pump.</li> </ul>
<b>Pump doesn't catch prime</b>	<ul style="list-style-type: none"> <li>• Excessive suction lift (*1).</li> </ul>	<ul style="list-style-type: none"> <li>• Move the pump closer to liquid source.</li> </ul>
<b>Priming takes a long time</b>	<ul style="list-style-type: none"> <li>• Suction line is quite long.</li> <li>• Air pockets or leaks may exist in the suction line.</li> </ul>	<ul style="list-style-type: none"> <li>• Refer to "start-up" under operation.</li> <li>• Check the line for loose connections.</li> </ul>
<b>Pump does not perform as well as it should</b>	<ul style="list-style-type: none"> <li>• Flow is restricted due to:                             <ul style="list-style-type: none"> <li>a) Debris build-up.</li> <li>b) Faulty or semi-open valve(s).</li> <li>c) Piping/hosing used is smaller than the thread sizes on the pump.</li> </ul> </li> <li>• Insufficient submergence of the end of the suction line.</li> <li>• Excessively worn impeller (*2).</li> <li>• Seal is damaged (*3). Liquid will be leaking through the middle of the adapter.</li> <li>• Air pockets or leaks in the suction line.</li> <li>• Clogged impeller.</li> </ul>	<ul style="list-style-type: none"> <li>a) Clean the lines and fittings.</li> <li>b) Check to see that the valves are in good working order.</li> <li>c) Increase the size of hose/pipe to reduce friction losses.</li> <li>• The end of the suction line must be submerged.</li> <li>• Replace impeller.</li> <li>• Replace seal.</li> <li>• Check suction line.</li> <li>• Remove casing to clean out.</li> </ul>
<b>Pump loses prime</b>	<ul style="list-style-type: none"> <li>• Liquid level drops below the end of the suction line.</li> </ul>	<ul style="list-style-type: none"> <li>• Increase length of suction line or if using flexible hose, you may be able to move the pump closer to the liquid source.</li> </ul>

**\*1)** Excessive suction lift, must take the following into consideration:

- a) Size and length of pipe
- b) Density and temperature of liquid
- c) Pipe fittings
- d) Elevation above sea level

Including all of the above, we recommend the total suction head not to exceed lift.

**\*2)** An excessively worn impeller is mainly caused from “cavitation”. Cavitation can be caused from a number of situations.

**Examples:**

- a) Restricted suction line
- b) Excessive suction lift

**\*3)** The seal may be damaged due to:

- a) Normal wear
- b) Overheating
- c) Pumping chemicals that this seal is not designed for

Contact your nearest Monarch Depot for any further assistance.

MONARCH INDUSTRIES  
51 Burmac Road, P.O. Box 429  
Winnipeg, Manitoba, Canada  
R3C 3E4

[www.monarchindustries.com](http://www.monarchindustries.com)

**LIMITED MONARCH INDUSTRIES WARRANTY**

For one year from date of purchase, Monarch Industries will replace or repair for the original purchaser, free of charge, any part or parts, found upon examination by any Monarch Industries Authorized Service Depot or by the Monarch factory, to be defective in material or workmanship or both. Equipment and accessories not manufactured by Monarch Industries are warranted only to the extent of the original manufacturer's warranty. All transportation charges on parts submitted for replacement or repair under this warranty must be borne by the purchaser. For warranty service see your nearest Monarch Industries Authorized Service Depot. THERE IS NO OTHER EXPRESS WARRANTY. IMPLIED WARRANTIES INCLUDING THOSE OF MERCHANTABILITY AND FITNESS FOR A PARTICULAR PURPOSE ARE LIMITED TO ONE YEAR FROM PURCHASE AND TO THE EXTENT PERMITTED BY LAW. LIABILITY FOR CONSEQUENTIAL DAMAGES UNDER ANY AND ALL WARRANTIES ARE EXCLUDED TO THE EXTENT EXCLUSION IS PERMITTED BY LAW. This warranty is an addition to any statutory warranty.